

Dec. 20, 2003



FTM-3012C-S20/FTM-3012C-L20

1.25G 1310nm SFP Transceiver

Members Of Flexon™ Family

Features

- ◆ 1310nm FP laser transmitter
- ◆ 550m with MMF
- ◆ 2m~20km with 9/125 μ m SMF
- ◆ Multi-source package with LC optical interface
- ◆ Optional spring latch for high density application
 - FTM-3012C-S20 standard structure
 - FTM-3012C-L20 with spring latch
- ◆ Up to 1.25Gbps bi-directional data links
- ◆ Single +3.3V power supply
- ◆ Hot-pluggable capability
- ◆ Low power dissipation
- ◆ Low EMI and excellent ESD protection
- ◆ Class 1 laser product
- ◆ Detailed product information in EEPROM
- ◆ Operating temperature range: 0°C to +70°C



Applications

FTM-3012C-S20/FTM-3012C-L20 SFP is well suited for Local Area Network (LAN) and Storage Area Network (SAN), typically used in:

- ◆ Switch to Switch interface
- ◆ Switched backplane applications
- ◆ Router/Server interface
- ◆ Other optical transmission systems

Standards

- ◆ Compliant with SFP MSA
- ◆ Compliant with IEEE 802.3z
- ◆ Compliant with ANSI specifications for Fibre Channel
- ◆ Compliant with FCC 47 CFR Part 15, Class B
- ◆ Compliant with FDA 21 CFR 1040.10 and 1040.11, Class I

Product Description

FTM-3012C-S20/FTM-3012C-L20 is compliant with the SFP MSA, and meets the requirements of IEEE 802.3 Gigabit Ethernet standard and ANSI specifications for Fibre Channel. Its primary application is serving Gigabit Ethernet and Fibre Channel links between optical networking equipments.

Its pluggable architecture allows this module to be installed into MSA standard SFP port at any time even with the host equipment operating online. This facilitates the rapid configuration of equipment to meet the user's needs precisely: reducing inventory costs and network downtime. Compared with traditional transceivers, the size of the Small Form Factor package enables higher port densities.

FTM-3012C-S20/FTM-3012C-L20 incorporates a highly reliable 1310nm Fabry-Perot (FP) laser in its transmitter section. This transceiver enables cost-effective data transmission over optical fibers at a distance of 550 meters with 62.5/125 μ m or 50/125 μ m multimode fiber and 20km with 9/125 μ m single-mode fiber respectively.

Low Power Dissipation

By utilizing the latest chipset technology, FTM-3012C-S20/FTM-3012C-L20 realizes low power dissipation. Typical working current is less than 200mA, at +3.3V operation, only 66.7% of the maximum current allowed by the SFP specification (300mA).

Hot-pluggable Capability

FTM-3012C-S20/FTM-3012C-L20 can be installed in or removed from any MSA compliant Pluggable Small Form Factor port regardless of whether the host equipment is operating or not. Controlled hot-plugging is ensured by 3-stage pin sequencing at the electrical interface.

As the FTM-3012C-S20/FTM-3012C-L20 is inserted, first contact is made by the housing ground shield, discharging any potential component-damaging static electricity. Ground pins engage next and then followed by power supplies. Finally, signal lines are connected.

Optional Spring latch For High Density Application

FTM-3012C-L20 features a spring latch that allows user to easily remove the SFP transceiver by hand in high-density application.

Detailed Product Information In EEPROM

FTM-3012C-S20/FTM-3012C-L20 features an EEPROM that contains the detailed product information stored for retrieval by host equipment. This information is accessed via the 2-wire

serial CMOS EEPROM protocol. For further information, please refer to SFP Multi-Source Agreement (MSA).

Block Diagram

This product consists of two basic parts: transmitter and receiver. They are illustrated in Figure 1.

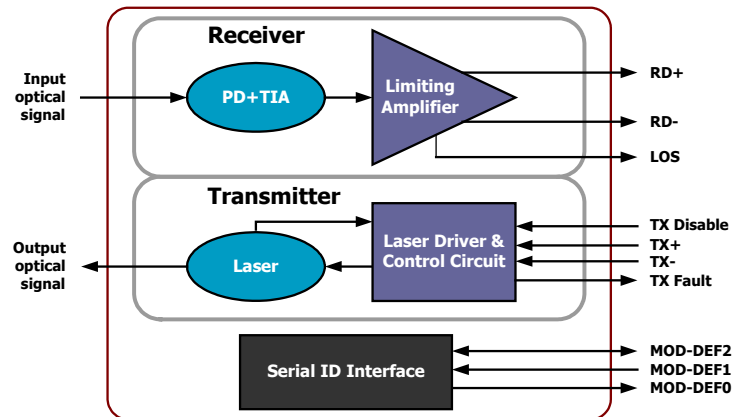

Figure 1, Product Block Diagram

Regulatory Compliance

This product has been tested according to American and European product safety and electromagnetic compatibility regulations (See Table 1). For further information regarding regulatory certification, please refer to Flexon™ regulatory specification and safety guidelines, or contact with Fiberxon, Inc. America sales office listed at the end of documentation.

Table 1 - Regulatory Compliance

Feature	Test Method	Target Performance
Electrostatic Discharge (ESD) to the Electrical Pins	MIL-STD-883E Method 3015.7	Class 2(>2000 V)
Electrostatic Discharge (ESD) to the Duplex LC Receptacle	Variation of IEC 61000-4-2	Typically withstand at least 15 kV without damage when port is contacted by a Human Body Model probe.
Electromagnetic Interference (EMI)	FCC Part 15 Class B CENELEC EN55022 Class B (CISPR 22B) VCCI Class B	Compliant with standards
Immunity	Variation of IEC 61000-4-3	Typically show no measurable effect from a 10 V/m field swept from 80 MHz to 1000 MHz applied to the transceiver without a chassis enclosure

Laser Eye Safety	FDA 21CFR 1040.10 and 1040.11 EN60950, EN(IEC)60825-1,2	AEL Class I, FDA/CDRH TUV Certificate No. 50030043
Component Recognition	UL and CSA	UL file E223705

Mechanical Design Diagram

The mechanical design diagram is shown in Figure 2 and Figure 3.

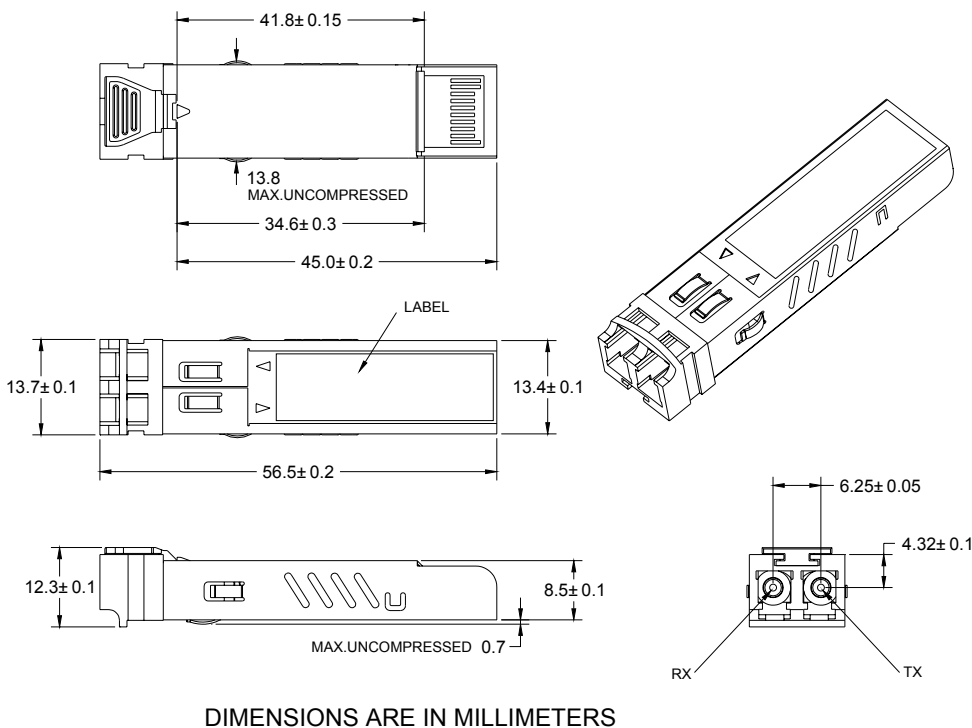

Figure 2, Mechanical Design Diagram of FTM-3012C-S20

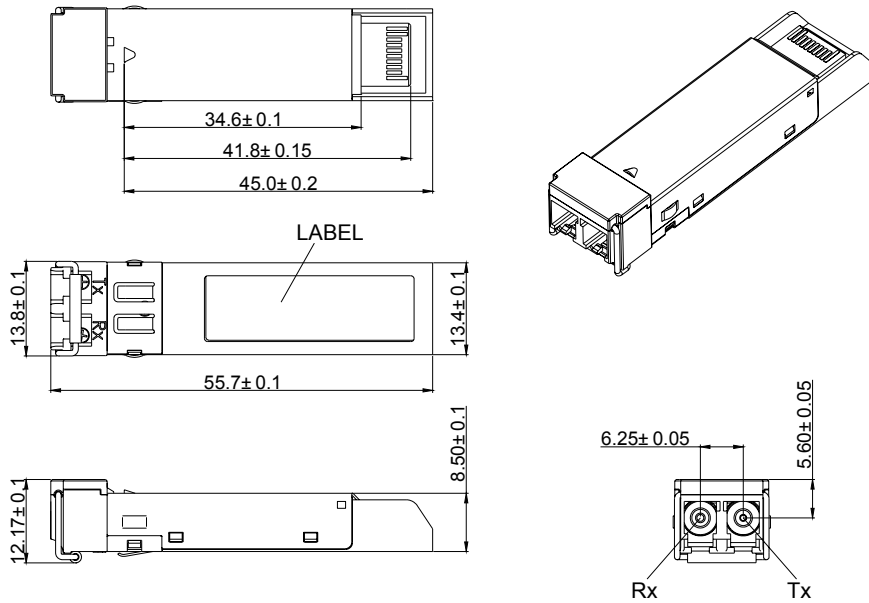

Figure 3, Mechanical Design Diagram of FTM-3012C-L20

Recommended Host Board Power Supply Circuit

FTM-3012C-S20/FTM-3012C-L20 is a hot pluggable SFP transceiver. Figure 4 shows the recommended host board power supply circuit.

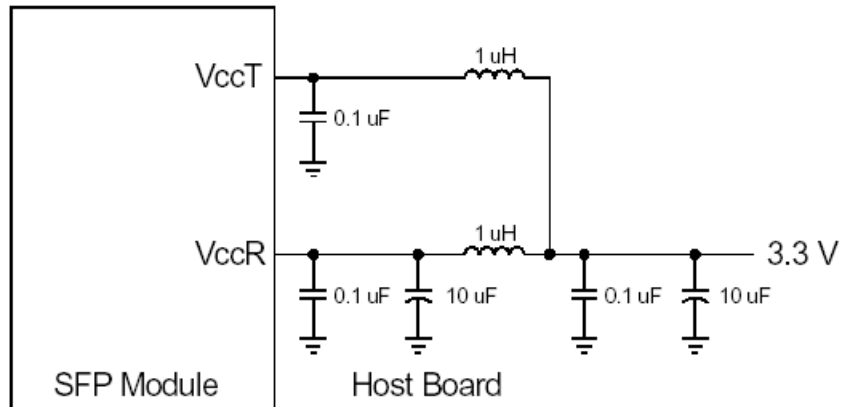
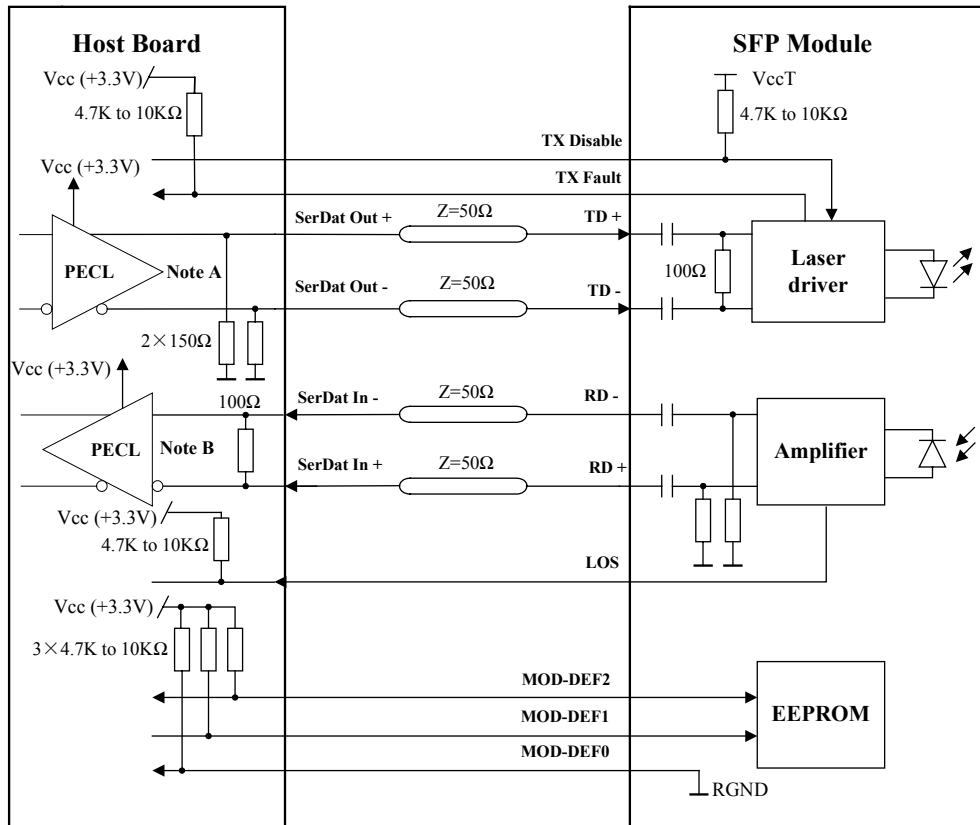

Figure 4, Recommended Host Board Power Supply Circuit

Recommended Interface Circuit

Figure 5 shows the recommended interface circuit.



Note A: Circuit assumes open emitter output

Note B: Circuit assumes high impedance internal bias @Vcc-1.3V

Figure 5, Recommended Interface Circuit

Absolute Maximum Ratings

Absolute Maximum Ratings are those values beyond which damage to the device may occur. Exposure to conditions above the Absolute Maximum Ratings listed in Table 2 may negatively impact the reliability of this product.

Table 2 – Absolute Maximum Ratings

Parameter	Symbol	Min.	Max.	Unit
Storage Temperature	T _S	-40	+85	°C
Supply Voltage	V _{CC}	-0.5	3.6	V
Voltage at any Input Pin	-	-0.5	V _{CC} +0.3	V
Operating Humidity	-	5	95	%

Recommended Operating Conditions

Functional operation of this device is implied at Recommended Operating Conditions (shown in Table 3).

Table 3 - Recommended Operating Conditions

Parameter		Symbol	Min.	Typical	Max.	Unit
Ambient Operating Temperature		T_A	0		+70	°C
Supply Voltage		V_{CC}	3.13		3.47	V
Data Rate	Gigabit Ethernet			1.25		Gbps
	Fibre Channel			1.0625		

Optical Characteristics

Table 4 lists the optical characteristics of FTM-3012C-S20/FTM-3012C-L20.

Table 4 – Optical Characteristics (0°C to +70°C, 3.13V to 3.47V)

Parameter	Symbol	Min.	Typical	Max.	Unit	Notes
Transmitter						
Centre Wavelength	λ_C	1270	1310	1355	nm	
Spectral Width (RMS)	σ		2		nm	
Output Power	P_{OUT}	-5.5		-3	dBm	1
Rise/Fall Time (20%~80%)	t_r/t_f			0.26	ns	2
Extinction Ratio	ER	9			dB	
Total Jitter	1.25G	TJ		0.431	UI	3
	1.0625G			0.43		
P_{OUT} @TX Disable Asserted				-45	dBm	
Receiver						
Centre Wavelength	λ_C	1260	1310	1570	nm	
Receiver Sensitivity				-20	dBm	4
Receiver Overload		-3			dBm	
Return Loss		12			dB	
LOS Assert		-35			dBm	
LOS De-Assert				-21	dBm	
LOS Hysteresis		1		4	dB	

Notes:

1. Measured average power coupled into SMF.
2. Unfiltered, measured with a PRBS 2^7-1 test pattern @1.25Gbps
3. Meet the specified maximum output jitter requirements if the specified maximum input jitter is present.
4. Measured with a PRBS 2^7-1 test pattern @1.25Gbps, BER better than or equal to 1×10^{-12} .

Electrical Characteristics

All the electrical interfaces are full compliant with SFP MSA specifications. The high speed DATA interface uses PECL signal that is AC-coupled. The low speed control and sense input/output signals are level compatible with TTL. Table 5 below shows the detailed electrical characteristics of this product.

Table 5 – Electrical Characteristics (0°C to +70°C, 3.13V to 3.47V)

Parameter	Symbol	Min.	Typical	Max.	Unit	Notes
Supply Voltage	V_{CC}	3.13		3.47	V	
Supply Current	I_{CC}		200	300	mA	
Transmitter						
Differential Data Input Swing	V_{IN}	300		1860	mV	1
Differential Input Impedance	Z_{IN}	90	100	110	Ω	
TX Disable	Disable		2.0	V_{CC}	V	2
	Enable		0	0.8	V	
TX Fault	Fault		2.0	$V_{CC}+0.3$	V	
	Normal		0	0.8	V	
TX Disable Assert Time	t_{off}			10	μ s	
Receiver						
Differential Data Output Swing	V_{OUT}	370		2000	mV	3
Total Jitter	1.25G	TJ		0.749	UI	4
	1.0625G			0.61		
LOS Output Voltage	High		2.0	$V_{CC}+0.3$	V	
	Low		0	0.8	V	

Notes:

1. Internally AC coupled and terminated (100 Ω differential).
2. If Pin 3 (TX Disable) is left open, TX is disabled.
3. Internally AC coupled, should be terminated with 100 Ω (differential).
4. Meet the specified maximum output jitter requirements if the specified maximum input jitter is present.

Pin Definitions

Figure 6 below shows the pin numbering of SFP electrical interface. The pin functions are described in Table 6 and the accompanying notes.

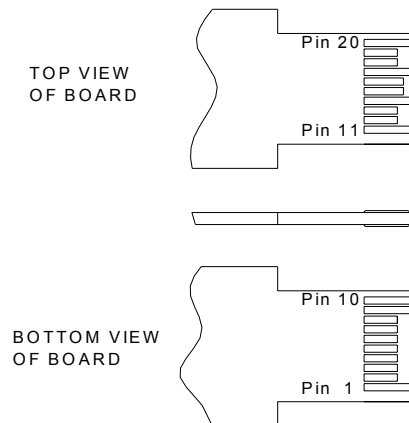

Figure 6, Pin View

FTM-3012C-S20/FTM-3012C-L20 has three stages of contact sequencing during insertion. The ground make contact at first in sequence stage 1, then followed by power supply in sequence stage 2, finally, signal lines engage in sequence stage 3. Conversely, when the module is plugged out from the host system, signal lines disengage firstly, then power supply and ground.

It is the responsibility of the system integrator to assure that no thermal, energy, or voltage hazard exists during the hot-plug-unplug sequence. It is also the responsibility of the system integrator and end-user to minimize static electricity and the probability of ESD events by careful design.

Table 6 – Pin Function Definitions

Pin No.	Name	Function	Plug Seq.	Notes
1	VeeT	Transmitter Ground	1	
2	TX Fault	Transmitter Fault Indication	3	Note 1
3	TX Disable	Transmitter Disable	3	Note 2
4	MOD-DEF2	Module Definition 2	3	Note 3
5	MOD-DEF1	Module Definition 1	3	Note 3
6	MOD-DEF0	Module Definition 0	3	Note 3
7	Rate Select	Not Connected	3	
8	LOS	Loss of Signal	3	Note 4
9	VeeR	Receiver Ground	1	
10	VeeR	Receiver Ground	1	
11	VeeR	Receiver Ground	1	
12	RD-	Inv. Received Data Out	3	Note 5
13	RD+	Received Data Out	3	Note 5
14	VeeR	Receiver Ground	1	
15	VccR	Receiver Power	2	
16	VccT	Transmitter Power	2	
17	VeeT	Transmitter Ground	1	

18	TD+	Transmit Data In	3	Note 6
19	TD-	Inv. Transmit Data In	3	Note 6
20	VeeT	Transmitter Ground	1	

Notes:

- TX Fault is an open collector output, which should be pulled up with a 4.7k~10kΩ resistor on the host board to a voltage between 2.0V and Vcc+0.3V. Logic 0 indicates normal operation; logic 1 indicates a laser fault of some kind. In the low state, the output will be pulled to less than 0.8V.
- TX Disable is an input that is used to shut down the transmitter optical output. It is pulled up within the module with a 4.7k~10kΩ resistor. Its states are:
Low (0~0.8V): Transmitter on
(>0.8V, <2.0V): Undefined
High (2.0~3.465V): Transmitter Disabled
Open: Transmitter Disabled
- MOD-DEF 0,1,2 are the module definition pins. They should be pulled up with a 4.7k~10kΩ resistor on the host board. The pull-up voltage shall be VccT or VccR.
MOD-DEF 0 is grounded by the module to indicate that the module is present
MOD-DEF 1 is the clock line of two wire serial interface for serial ID
MOD-DEF 2 is the data line of two wire serial interface for serial ID
- LOS is an open collector output, which should be pulled up with a 4.7k~10kΩ resistor on the host board to a voltage between 2.0V and Vcc+0.3V. Logic 0 indicates normal operation; logic 1 indicates loss of signal. In the low state, the output will be pulled to less than 0.8V.
- These are the differential receiver outputs. They are AC coupled 100Ω differential lines which should be terminated with 100Ω (differential) at the user SERDES.
- These are the differential transmitter inputs. They are AC-coupled, differential lines with 100Ω differential termination inside the module.

Ordering Information

Part No.	Product Description
FTM-3012C-S20	1310nm 1.25/1.0625Gbps 20km SFP, T _A =0 to 70°C
FTM-3012C-L20	1310nm 1.25/1.0625Gbps 20km SFP with Spring latch, T _A =0 to 70°C

Related Documents

For further information, please refer to the following documents:

- *Flexon™ SFP Installation Guide*
- *Flexon™ SFP Application Notes*
- *SFP Multi-Source Agreement (MSA)*

Obtaining Document

You can visit our website:

<http://www.fiberxon.com>

Or contact with the Fiberxon, Inc. America sales office listed at the end of documentation to get latest documents.

© Copyright Fiberxon Inc. 2003

All Rights Reserved.

All information contained in this document is subject to change without notice. The products described in this document are NOT intended for use in implantation or other life support applications where malfunction may result in injury or death to persons.

The information contained in this document does not affect or change Fiberxon's product specifications or warranties. Nothing in this document shall operate as an express or implied license or indemnity under the intellectual property rights of Fiberxon or third parties. All information contained in this document was obtained in specific environments, and is presented as an illustration. The results obtained in other operating environment may vary.

THE INFORMATION CONTAINED IN THIS DOCUMENT IS PROVIDED ON AN "AS IS" BASIS. In no event will Fiberxon be liable for damages arising directly from any use of the information contained in this document.

Contact

U.S.A. Headquarter:

5201 Great America Parkway, Suite 350

Santa Clara, CA 95054

U. S. A.

Tel: 408-562-6288

Fax: 408-562-6289

Or visit our website: <http://www.fiberxon.com>