

Nov. 24, 2003



FTM-5012S-G50

1.25G 1550nm Gigabit Interface Converter

Members Of Flexon™ Family

Features

- ◆ Up to 50km transmission distance with SMF
- ◆ 1550nm DFB laser transmitter
- ◆ Standard GBIC footprint with SC optical interface
- ◆ Optional plastic or metal enclosure
- ◆ Up to 1.25Gbps bi-directional data links
- ◆ Hot-pluggable capability
- ◆ Low power dissipation
- ◆ Low EMI and excellent ESD protection
- ◆ Class 1 laser product
- ◆ Extended power supply +3.3/5.0V compatible
- ◆ Detailed product parameters in EEPROM



Applications

FTM-5012S-G50 GBIC is well suited for Metropolitan Area Network (MAN) and Storage Area Network (SAN) where long-haul transmission is needed, typically used in:

- ◆ Switch to Switch interface
- ◆ Switched backplane applications
- ◆ Router/Server interface
- ◆ Other optical transmission systems

Standards

- ◆ Compliant with GBIC specification (SFF-8053), Rev 5.5
- ◆ Compliant with IEEE 802.3z
- ◆ Compliant with ANSI specifications for Fibre Channel
- ◆ Compliant with FCC 47 CFR Part 15, Class B
- ◆ Compliant with FDA 21 CFR 1040.10 and 1040.11, Class I

Product Description

FTM-5012S-G50 is fully compliant with Gigabit Interface Converter (GBIC) specification (SFF-8053), Rev5.5. It can be inserted in or removed from host chassis without shutting power of the host system.

This GBIC transceiver meets the requirements of IEEE 802.3 Gigabit Ethernet standard and is compliant with ANSI Fibre Channel specifications. Its primary application is serving Gigabit Ethernet and Fibre Channel links between optical networking equipments.

FTM-5012S-G50 incorporates a highly reliable 1550nm DFB laser in its transmitter section. It enables cost-effective data transmission over optical fibers at a distance of 50km with 9/125 μ m single-mode fiber.

Optional Plastic or Metal Enclosure

FTM-5012S-G50 is available in optional plastic or metal enclosure.

Low Power Dissipation

By utilizing the latest chipset technology, FTM-5012S-G50 realizes low power dissipation. Typical current is 220mA when operating at 3.1V~5.5V, only 73.3% of the maximum current allowed by the GBIC specification (300mA).

Flexibility

FTM-5012S-G50 patent mechanical design can guarantee excellent EMC/EMI performance. The innovative mechanical design allows user to easily install and remove the GBIC transceiver by hand.

Detailed Product Information In EEPROM

FTM-5012S-G50 complies with Module Definition 4. It features an EEPROM that contains the detailed product information stored for retrieval by host equipment. This information is accessed via the 2-wire serial CMOS EEPROM protocol of ATMEL AT24C02. For further information, please refer to GBIC specification, Rev 5.5.

Block Diagram

Figure 1 illustrates the block diagram of this product.

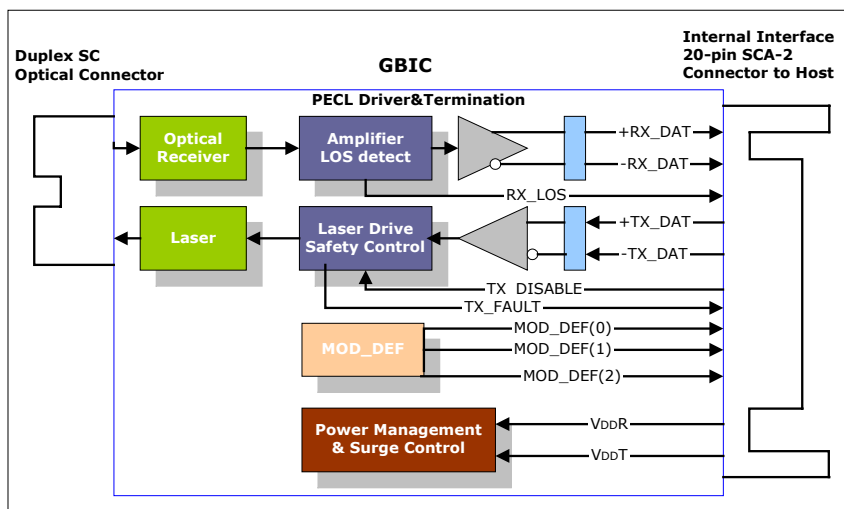

Figure 1, Product Block Diagram

Regulatory Compliance

This product has been tested according to American and European product safety and electromagnetic compatibility regulations (See Table 1). For further information regarding regulatory certification, please refer to Flexon™ regulatory specification and safety guidelines, or contact with Fiberxon, Inc. America sales office listed at the end of documentation.

Table 1 - Regulatory Compliance

Feature	Test Method	Target Performance
Electrostatic Discharge (ESD) to the Electrical Pins	MIL-STD-883E Method 3015.7	Class 2(>2000 V)
Electrostatic Discharge (ESD) to the Duplex SC Receptacle	Variation of IEC 61000-4-2	Typically withstand at least 15 kV without damage when port is contacted by a Human Body Model probe.
Electromagnetic Interference (EMI)	FCC Part 15 Class B CENELEC EN55022 Class B (CISPR 22B) VCCI Class B	Compliant with standards
Immunity	Variation of IEC 61000-4-3	Typically show no measurable effect from a 10 V/m field swept from 80 MHz to 1000 MHz applied to the transceiver without a chassis enclosure
Laser Eye Safety	FDA 21CFR 1040.10 and 1040.11 EN60950, EN(IEC)60825-1,2	AEL Class I, FDA/CDRH AEL Class 1, TUV Rheinland of North America
Component Recognition	UL and CSA	

Mechanical Design Diagram

The mechanical design diagram is shown in Figure 2 and Figure 3.

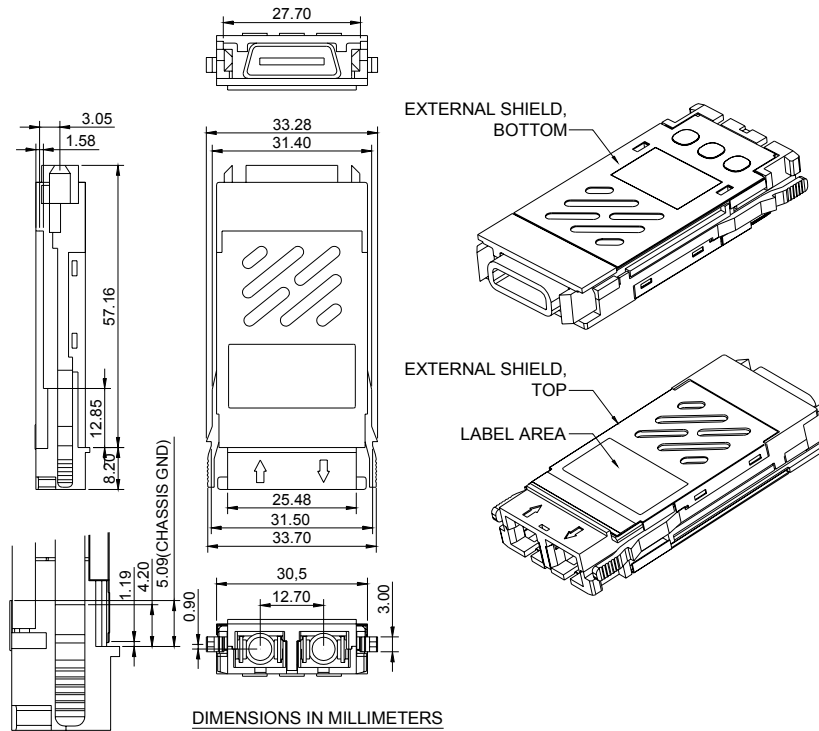

Figure 2, Mechanical Design Diagram for Plastic Enclosure

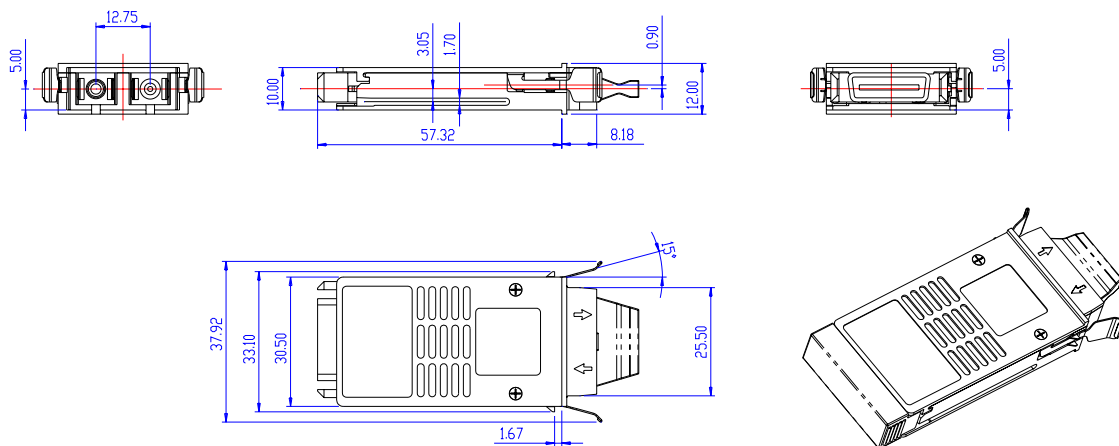
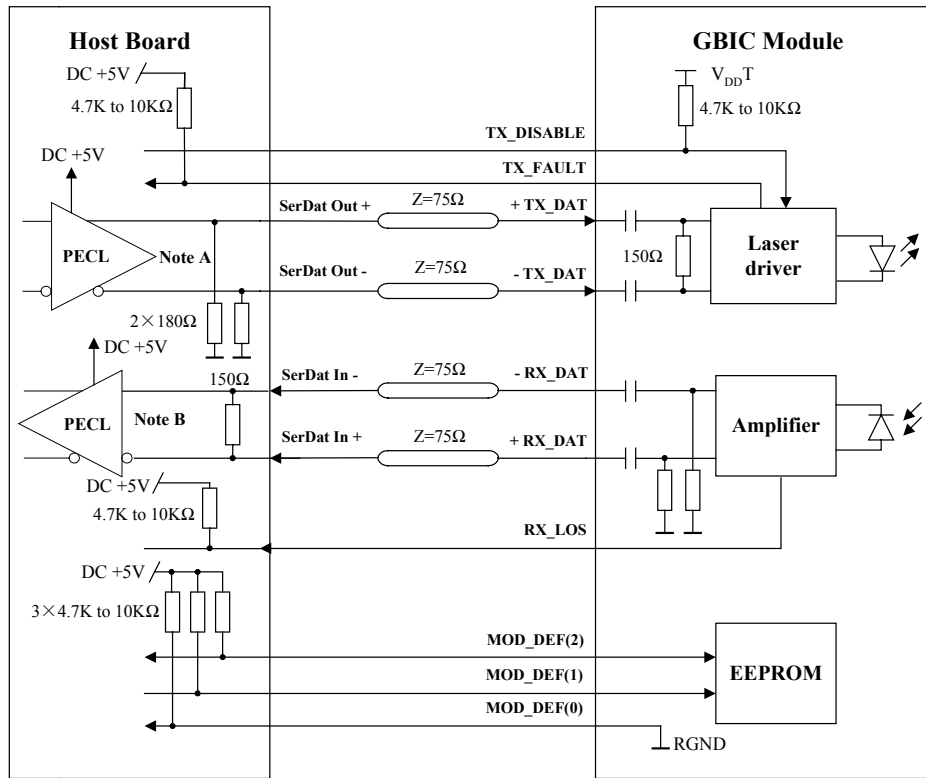

Figure 3, Mechanical Design Diagram for Metal Enclosure (Dimension in mm)

Recommended Interface Circuit

Figure 4 shows the recommended interface circuit for GBIC application.



Note A: Circuit assumes open emitter output
 Note B: Circuit assumes high impedance internal bias @Vcc-1.3V

Figure 4, Recommended Interface Circuit

Absolute Maximum Ratings

Absolute Maximum Ratings are those values beyond which damage to the device may occur. Exposure to conditions above the Absolute Maximum Ratings listed in Table 2 may negatively impact the reliability of this product.

Table 2 – Absolute Maximum Ratings

Parameter	Symbol	Min.	Max.	Unit
Storage Temperature	T _S	-40	+85	°C
Supply Voltage	V _{CC}	-0.5	6.0	V
Voltage at any Input Pin	-	-0.5	V _{CC} +0.3	V
Operating Humidity	-	5	95	%

Recommended Operating Conditions

Functional operation of this device is implied at Recommended Operating Conditions (shown in Table 3).

Table 3 - Recommended Operating Conditions

Parameter		Symbol	Min.	Typical	Max.	Unit
Ambient Operating Temperature		T_A	0		+70	°C
Supply Voltage		V_{CC}	3.1		5.5	V
Data Rate	Gigabit Ethernet			1.25		Gbps
	Fibre Channel			1.0625		

Optical Characteristics

Table 4 lists the optical characteristics of FTM-5012S-G50.

Table 4 – Optical Characteristics (0°C to 70°C, 3.1V to 5.5V)

Parameter		Symbol	Min.	Typical	Max.	Unit	Notes	
Transmitter								
Centre Wavelength		λ_c	1530	1550	1570	nm		
Spectral Width (-20dB)		$\Delta\lambda$			1	nm		
Output Power		P_{OUT}	-5		0	dBm	1	
Rise/Fall Time (20%~80%)		t_r/t_f			0.26	ns	2	
Extinction Ratio		ER	9			dB		
Total Jitter	1.25G	TJ			0.431	UI	3	
	1.0625G				0.43			
Deterministic Jitter	1.25G	DJ			0.2	UI	3	
	1.0625G				0.21			
P_{OUT} @TX Disable Asserted					-45	dBm		
Output Optical Eye		IEEE 802.3z and ANSI Fibre Channel Compliant						4
Receiver								
Centre Wavelength		λ_c	1200		1660	nm		
Receiver Sensitivity					-22	dBm	5	
Receiver Overload			-3			dBm		
Return Loss			12			dB		
LOS Assert			-35			dBm		
LOS De-Assert					-24	dBm		
LOS Hysteresis			1		4	dB		

Notes:

1. Measured average power coupled into SMF.
2. Unfiltered, measured with a PRBS 2^7-1 test pattern @1.25Gbps
3. Meet the specified maximum output jitter requirements if the specified maximum input jitter is present.
4. Measured with a PRBS 2^7-1 test pattern @1.25/1.0625Gbps.
5. measured with a PRBS 2^7-1 test pattern @1.25Gbps, BER better than or equal to 1×10^{-12}

Electrical Characteristics

All the signal interfaces are full compliant with GBIC specification Rev. 5.5. The high speed DATA interface uses PECL signal that is AC-coupled. The low speed control and sense input/output signals are level compatible with TTL. Table 5 below shows the detailed electrical characteristics of this product.

Table 5 – Electrical Characteristics (0°C to 70°C, 3.1V to 5.5V)

Parameter	Symbol	Min.	Typical	Max.	Unit	Notes
Transceiver Power Supply						
Supply Voltage	V_{CC}	3.1		5.5	V	
Supply Current	I_{CC}		220		mA	
Surge Current	I_{surge}			30	mA	
Transmitter						
Differential Data Input Swing	V_{IN}	650		1860	mV	1
Differential Input Impedance	Z_{IN}	140	150	160	Ω	
TX Disable	Disable	2.0		$V_{CC}+0.3$	V	
	Enable	0		0.8	V	
TX Fault	Fault	$host_V_{CC}-0.5$		$host_V_{CC}+0.3$	V	
	Normal	0		0.5	V	
TX Disable Assert Time	t_{off}			10	μs	
Receiver						
Differential Data Output Swing	V_{OUT}	370		2000	mV	2
Total Jitter	1.25G	TJ		0.749	UI	3
	1.0625G			0.61		
Deterministic Jitter	1.25G	TJ		0.462	UI	3
	1.0625G			0.36		
LOS Output Voltage	High		$host_V_{CC}-0.5$	$host_V_{CC}+0.3$	V	
	Low		0	0.5	V	

Notes:

1. Internally AC coupled and terminated (150 Ω differential).
2. Internally AC coupled, should be terminated with 150 Ω (differential).
3. Meet the specified maximum output jitter requirements if the specified maximum input jitter is present.

Pin Definitions

Figure 5 below shows the pin numbering of GBIC electrical interface. The pin functions are described in Table 6.

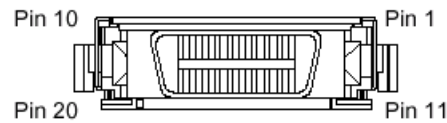

Figure 5, Pin View

It is the responsibility of the system integrator to assure that no thermal, energy, or voltage hazard exists during the hot-plug-unplug sequence. It is also the responsibility of the system integrator and end-user to minimize static electricity and the probability of ESD events by careful design.

Table 6 – Pin Function Definitions

Pin Name	Pin #	Name/Function	Signal Specification
RECEIVER SIGNALS			
RGND	2, 3, 11, 14	Receiver Ground (may be connected with TGND in GBIC)	Ground, to GBIC
V _{DDR}	15	Receiver +3.3/5 volt (may be connected with V _{DDT} in GBIC)	Power, to GBIC
-RX_DAT	12	Receive Data, Differential PECL	High speed serial, from GBIC
+RX_DAT	13	Receive Data, Differential PECL	High speed serial, from GBIC
RX_LOS	1	Receiver Loss of Signal, logic high, open collector compatible, 4.7k to 10kΩ pull up to V _{DDT} on host	Low speed, from GBIC
TRANSMITTER SIGNALS			
TGND	8, 9, 17, 20	Transmitter Ground (may be connected with RGND internally)	Ground, to GBIC
V _{DDT}	16	Transmitter +3.3/5 volt (may be connected with V _{DDR} in GBIC)	Power, to GBIC
+TX_DAT	18	Transmit Data, Differential PECL	High speed serial, to GBIC
-TX_DAT	19	Transmit Data, Differential PECL	High speed serial, to GBIC
TX_DISABLE	7	Transmitter Disable, logic high, open collector compatible, 4.7k to 10kΩ pull up to V _{DDT} on GBIC	Low speed, to GBIC
TX_FAULT	10	Transmitter Fault, logic high, open collector compatible, 4.7k to 10kΩ pull up to V _{DDT} on host	Low speed, from GBIC

CONTROL SIGNALS			
MOD_DEF(0)	4	TTL low, output	Please reference GBIC standard, Annex D: Module definition "4"
MOD_DEF(1)	5	SCL serial clock signal, input	
MOD_DEF(2)	6	SDA serial data signal, input/output	

Eye Diagram

Figure 6 shows the typical eye diagrams of this product.

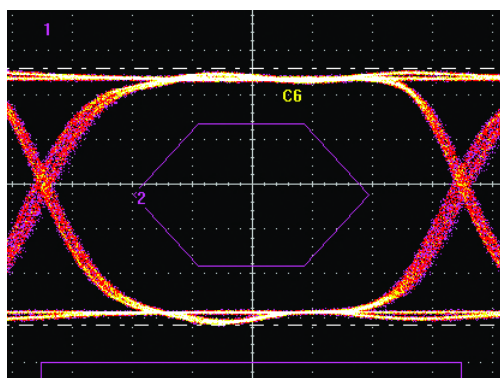

Receiver @ 1.25Gbps, 2^7-1 PRBS

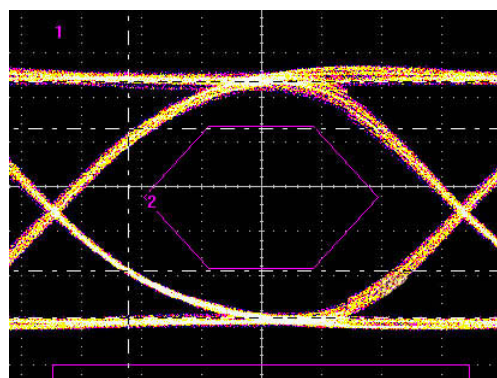

Transmitter @ 1.25Gbps, 2^7-1 PRBS

Figure 6, Typical Eye Diagrams

Ordering Information

Part No.	Application	Data Rate	Laser Source	Fiber Type	Distance
FTM-5012S-G50	Gigabit Ethernet Fibre Channel	1.25G 1.0625G	1550nm DFB	SMF	50km

Related Documents

For further information of Flexon™ GBIC for Gigabit Ethernet application, please refer to the following documents:

- *Flexon™ GBIC Installation Guide*
- *Flexon™ GBIC Application Notes*
- *SFF-8053, Proposed Specification for GBIC (Gigabit Interface Converter), Rev 5.5*

Obtaining Document

You can visit our website:

<http://www.fiberxon.com>

Or contact with Fiberxon, Inc. America sales office listed at the end of documentation to get the latest documents.

© Copyright Fiberxon Inc. 2003

All Rights Reserved.

All information contained in this document is subject to change without notice. The products described in this document are NOT intended for use in implantation or other life support applications where malfunction may result in injury or death to persons.

The information contained in this document does not affect or change Fiberxon's product specifications or warranties. Nothing in this document shall operate as an express or implied license or indemnity under the intellectual property rights of Fiberxon or third parties. All information contained in this document was obtained in specific environments, and is presented as an illustration. The results obtained in other operating environment may vary.

THE INFORMATION CONTAINED IN THIS DOCUMENT IS PROVIDED ON AN "AS IS" BASIS. In no event will Fiberxon be liable for damages arising directly from any use of the information contained in this document.

Contact

U.S.A. Headquarter:

5201 Great America Parkway, Suite 350

Santa Clara, CA 95054

U. S. A.

Tel: 408-562-6288

Fax: 408-562-6289

Or visit our website: <http://www.fiberxon.com>