





## **Contents**

1. Amulet On-Board Module Information
2. Precautions in Use of Amulet On-Board Module
3. General Specification
4. Absolute Maximum Ratings & Electrical Characteristics
5. Optical Characteristics
6. Interface Description
7. Contour Drawing
8. Quality Assurance
9. Reliability
10. Backlight Information
11. Touch Panel Information

# **1. Amulet On-Board Module Information**

MK-AOB 320240 5 B  
1            2            3 4

1 Product Type:            Amulet On-Board Module  
2 Display Resolution:    320 x 240 Pixels  
3 Display Type:            5.7" Graphic LCD  
4 Display Modes:         **B**= STN Negative, Blue, Transmissive  
                                 **N**= FSTN Negative, Transmissive  
                                 **T**= FSTN Positive, Transflective

Backlight Type:            White LED  
Backlight Control:        Digital Potentiometer  
Contrast Control:         Digital Potentiometer  
Viewing Angle:            6 o'clock  
Operating Temp:           -20°C to 70°C  
Temperature Comp:        Yes  
Power Requirement:       5Vdc (±.25v) @ 250mA

## **Memory**

µHTML Storage Capacity: 4 megabit

## **Communication Interface**

Communication Type:     Amulet Protocol via UART  
Data Rate (BAUD):        9,600 / 19,200 / 57,600 / 115,200 bps

## 2. Precautions in Use of Amulet On-Board Module

- Avoid applying excessive shocks to the module or making any alterations or modifications to it.
- Do not make extra holes on the printed circuit board, modify its shape or change any components.
- Do not disassemble the module.
- Do not operate it above the absolute maximum ratings.
- Do not drop, bend or twist module.
- Storage: Store in anti-static electricity container and in a clean environment.

## 3. General Specification

ITEM	STANDARD VALUE	UNIT
Number of Pixels	320 x 240	dots
Outline Dimension	160.0(W) x 109.0(H) x 11.4max(T)	mm
View Area	122.0(W) x 92.0(H)	mm
Active Area	119.2(W) x 90.3(H)	mm
Dot Size	0.34(W) x 0.34(H)	mm
Dot Pitch	0.36(W) x 0.36(H)	mm
LCD Type	<b>B</b> = STN Negative, Blue, Transmissive <b>N</b> = FSTN Negative, Transmissive <b>T</b> = FSTN Positive, Transflective	
View Direction	6 o'clock	
Backlight	White LED	

## 4. Absolute Maximum Ratings & Electrical Characteristics

ITEM	SYMBOL	MIN.	TYP.	MAX.	UNIT
Operating Temperature	T <sub>OP</sub>	-20	-	+70	°C
Storage Temperature	T <sub>ST</sub>	-30	-	+80	°C
Logic Voltage	V <sub>DD</sub>	-	3.3	3.46	V
Supply Voltage For Module	V <sub>CC</sub>	4.75	5.00	5.25	V
<b>CMOS Input</b>					
Input High Voltage	V <sub>IH</sub>	0.7V <sub>DD</sub>	-	-	V
Input Low Voltage	V <sub>IL</sub>	-	-	0.3V <sub>DD</sub>	V
Input Leakage Current	I <sub>L</sub>	-10	-	10	μA
<b>CMOS Output</b>					
Output High Voltage	V <sub>OH</sub>	0.8V <sub>DD</sub>	-	-	V
Output Low Voltage	V <sub>OL</sub>	-	-	0.5V <sub>DD</sub>	V
I/O Pin Pull-up Resistor	R <sub>IO</sub>	70K	108K	202K	Ω
Supply Current		240	250	270	mA

## 5. Optical Characteristics

ITEM	SYMBOL	CONDITION	MIN	TYP	MAX	UNIT
View Angle	(V) $\theta$	CR $\geq$ 2	30	-	60	deg.
	(H) $\phi$	CR $\geq$ 2	-45	-	45	deg.
Contrast Ratio	CR	-	-	5	-	-
Response Time	T rise	-	-	200	300	ms
	T fall	-	-	150	200	ms

### 5.1 Definitions

#### ■View Angles

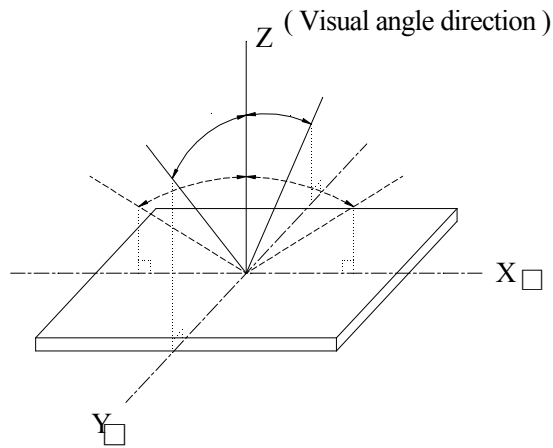

#### ■Contrast Ratio

$$CR = \frac{\text{Brightness at selected state (BS)}}{\text{Brightness at non-selected state (Bns)}}$$

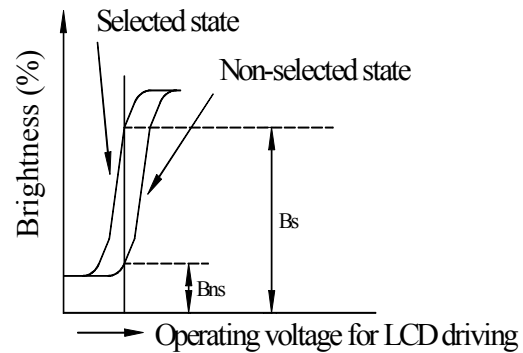

#### ■Response time

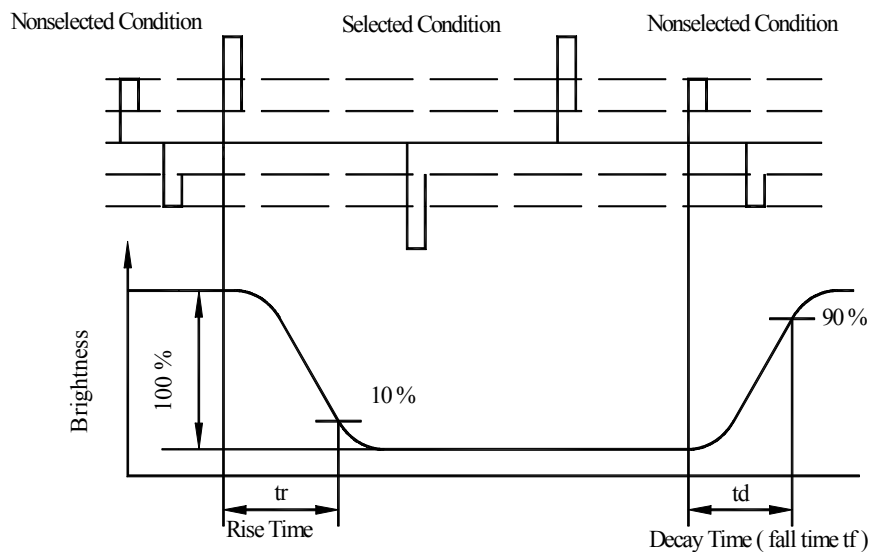

## 6. Interface Description

### Pin Type

I = CMOS Input  
 O = CMOS Output  
 P = Power Supply

Pin #	Signal	Type	Description
1	GND	P	Ground.
2	GND	P	Ground.
3	/FSS	O	Flash slave select. This pin should be left unconnected.
4	TXD	O	Asynchronous data output (UART Transmit).
5	/TSS	O	Touch panel slave select. This pin should be left unconnected.
6	RXD	I	Asynchronous data input (UART Receive).
7	/SS2	O	Contrast control slave select. This pin should be left unconnected.
8	GND	P	Ground.
9	/SS3	O	Backlight control slave select. This pin should be left unconnected.
10	BOOT MODE	I	<sup>2</sup> System power up mode. Drive high or leave unconnected to enter program mode or drive low for normal operation.
11	/SS4	O	SPI slave select 4. This pin is for future use and should be left unconnected.
12	TPC	I	<sup>2</sup> Touch panel calibration mode. Drive high or leave unconnected to enter calibration mode or drive low for normal operation.
13	/SS5	O	SPI slave select 5. This pin is for future use and should be left unconnected.
14	FBS	I	<sup>2</sup> Flash programming baud rate. Drive high or leave unconnected to program flash at 115,200 bps or drive low to program at 19,200 bps.
15	/SS6	O	SPI slave select 6. This pin is for future use and should be left unconnected.
16	GND	P	Ground.
17	/SS7	O	SPI slave select 7. This pin is for future use and should be left unconnected.
18	/RESET	I	System reset input. An external source can initiate a system reset by driving this pin low.
19	GND	P	Ground.
20	/IRQ	I	Touch panel interrupt. This pin should be left unconnected.
21	SCLK	O	SPI clock. This pin should be left unconnected.
22	GND	P	Ground.
23	MISO	I	SPI data in. This pin should be left unconnected.
24	GND	P	Ground.
25	MOSI	O	SPI data out. This pin should be left unconnected.
26	GND	P	Ground.
27	GND	P	Ground.

28	V <sub>CC</sub>	P	<sup>3</sup> Supply voltage for module. A regulated voltage between 4.75V and 5.25V should be applied to this pin.
29	GND	P	Ground.
30	V <sub>CC</sub>	P	<sup>3</sup> Supply voltage for module. A regulated voltage between 4.75V and 5.25V should be applied to this pin.

<sup>1</sup> The I/O pins must adhere to the voltage levels depicted in Section 4 (Absolute Maximum Ratings & Electrical Characteristics).

<sup>2</sup> Input pin is only read upon power up or a system reset.

<sup>3</sup> Supply voltage must provide 5V @ 250mA.

## 6.1 Typical Interface

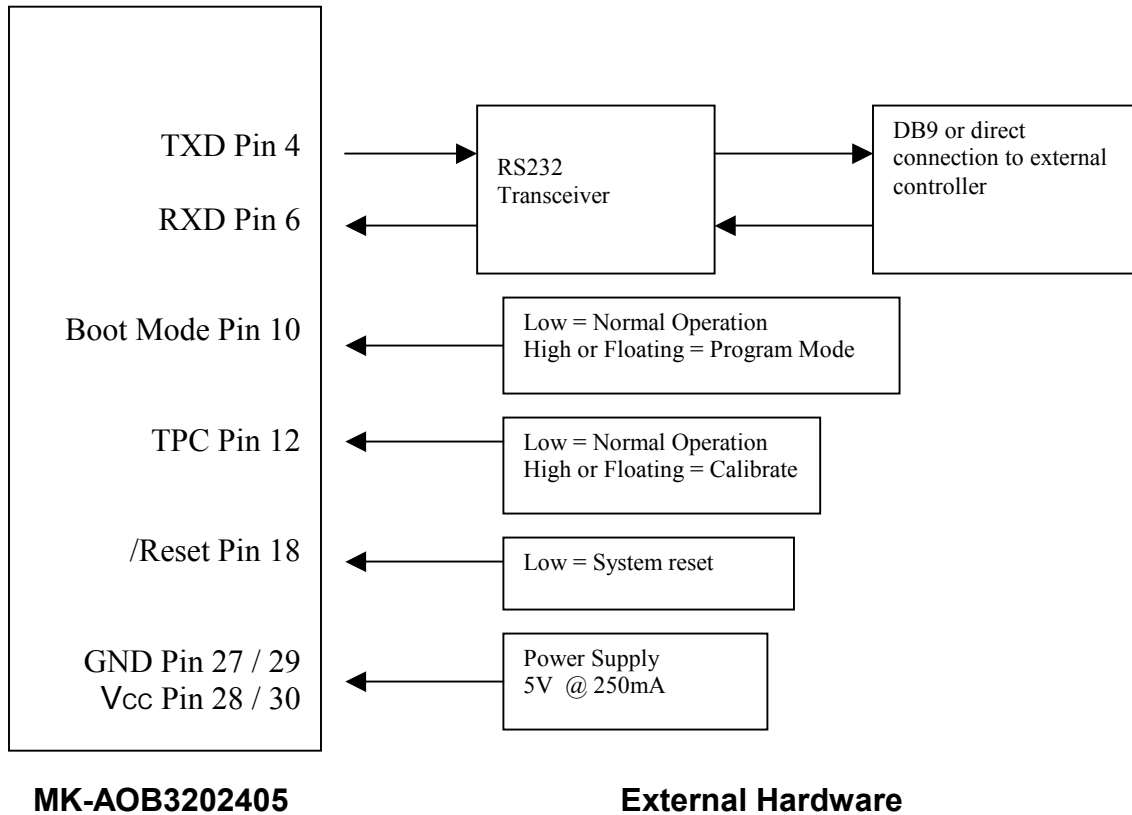

# 7. Contour Drawing

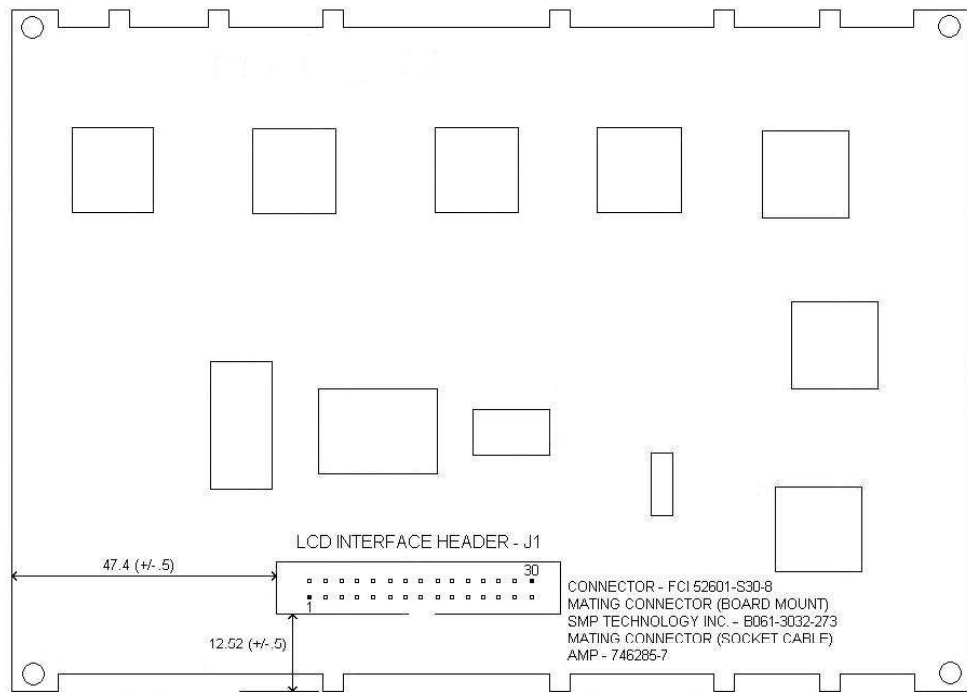
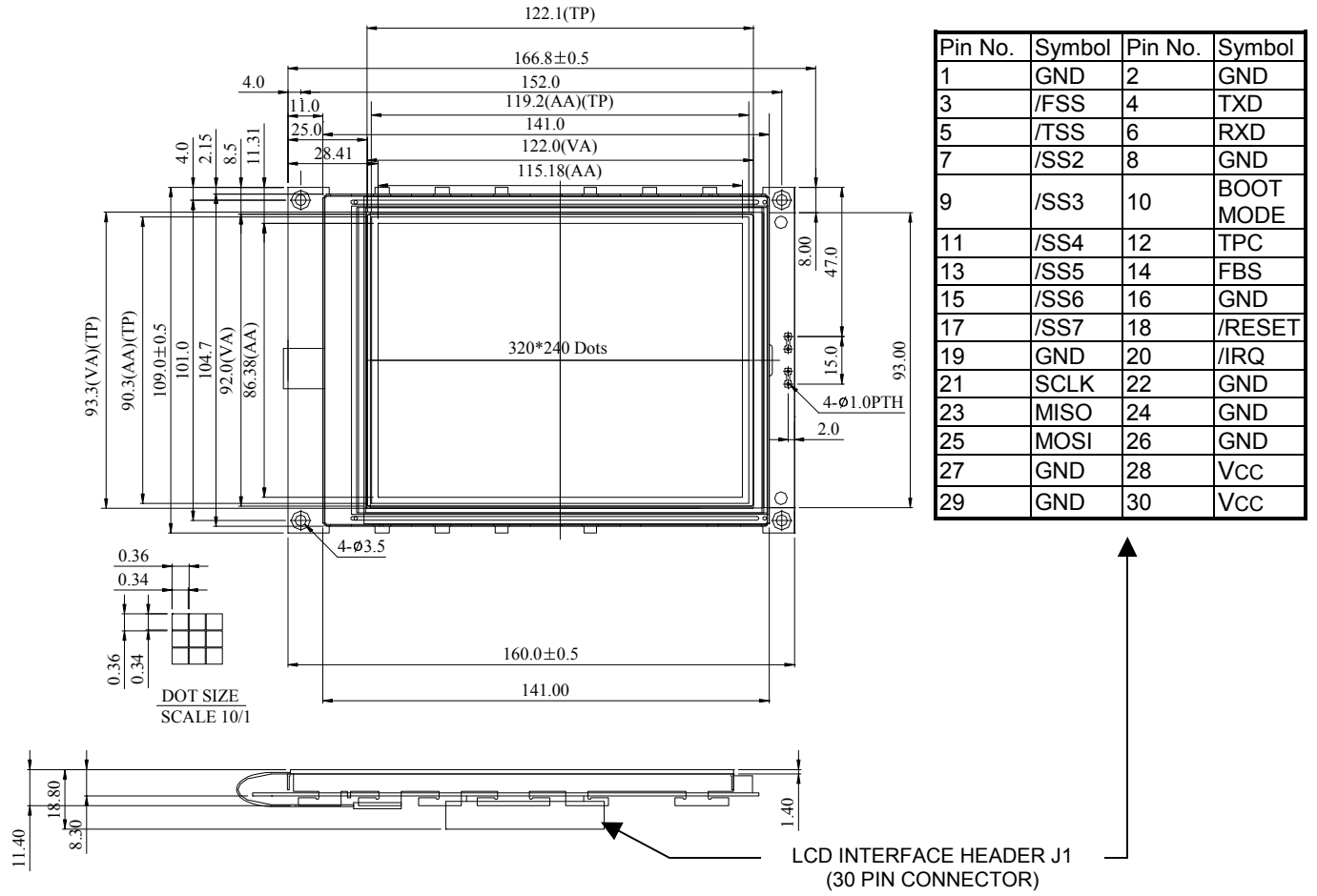

## 8. Quality Assurance

### Screen Cosmetic Criteria

NO.	DEFECT	JUDGMENT CRITERION	PARTITION																
1	Spots	<p>A) Clear</p> <p>Size: d mm    Acceptable Qty in active area</p> <table> <tr> <td><math>d \leq 0.1</math></td> <td>Disregard</td> </tr> <tr> <td><math>0.1 &lt; d \leq 0.2</math></td> <td>6</td> </tr> <tr> <td><math>0.2 &lt; d \leq 0.3</math></td> <td>2</td> </tr> <tr> <td><math>0.3 &lt; d</math></td> <td>0</td> </tr> </table> <p>Note: Including pinholes and defective dots, which must be within one pixel size.</p> <p>B) Unclear</p> <p>Size: d mm    Acceptable Qty in active area</p> <table> <tr> <td><math>d \leq 0.2</math></td> <td>Disregard</td> </tr> <tr> <td><math>0.2 &lt; d \leq 0.5</math></td> <td>6</td> </tr> <tr> <td><math>0.5 &lt; d \leq 0.7</math></td> <td>2</td> </tr> <tr> <td><math>0.7 &lt; d</math></td> <td>0</td> </tr> </table>	$d \leq 0.1$	Disregard	$0.1 < d \leq 0.2$	6	$0.2 < d \leq 0.3$	2	$0.3 < d$	0	$d \leq 0.2$	Disregard	$0.2 < d \leq 0.5$	6	$0.5 < d \leq 0.7$	2	$0.7 < d$	0	Minor
$d \leq 0.1$	Disregard																		
$0.1 < d \leq 0.2$	6																		
$0.2 < d \leq 0.3$	2																		
$0.3 < d$	0																		
$d \leq 0.2$	Disregard																		
$0.2 < d \leq 0.5$	6																		
$0.5 < d \leq 0.7$	2																		
$0.7 < d$	0																		
2	Bubbles in polarizer	<p>Size: d mm    Acceptable Qty in active area</p> <table> <tr> <td><math>d \leq 0.3</math></td> <td>Disregard</td> </tr> <tr> <td><math>0.3 &lt; d \leq 1.0</math></td> <td>3</td> </tr> <tr> <td><math>1.0 &lt; d \leq 1.5</math></td> <td>1</td> </tr> <tr> <td><math>1.5 &lt; d</math></td> <td>0</td> </tr> </table>	$d \leq 0.3$	Disregard	$0.3 < d \leq 1.0$	3	$1.0 < d \leq 1.5$	1	$1.5 < d$	0	Minor								
$d \leq 0.3$	Disregard																		
$0.3 < d \leq 1.0$	3																		
$1.0 < d \leq 1.5$	1																		
$1.5 < d$	0																		
3	Scratch	In accordance with spots cosmetic criteria. When the light reflects on the panel surface, the scratches are not to be remarkable.	Minor																
4	Allowable density	Above defects should be separated by more than 30mm from each other.	Minor																
5	Coloration	Not to be noticeable in the viewing area of the LCD panels. Backlight type should be judged with the backlight in the on state only.	Minor																

## 9. Reliability

### Content of Reliability Test

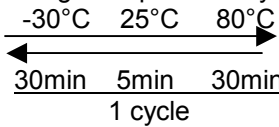
Environmental Test				
NO.	TEST ITEM	CONTENT OF TEST	TEST CONDITION	APPLICABLE STANDARD
1	High temperature storage	Endurance test applying the high storage temperature for a long time.	80°C 200hrs	—
2	Low temperature storage	Endurance test applying the low storage temperature for a long time.	-30°C 200hrs	—
3	High temperature operation	Endurance test applying the electric stress (Voltage & Current) and the thermal stress to the element for a long time.	70°C 200hrs	—
4	Low temperature operation	Endurance test applying the electric stress under low temperature for a long time.	-20°C 200hrs	—
5	High temperature/humidity storage	Endurance test applying the high temperature and high humidity storage for a long time.	80°C,90%RH 96hrs	—
6	High temperature/humidity operation	Endurance test applying the electric stress (Voltage & Current) and temperature / humidity stress to the element for a long time.	70°C,90%RH 96hrs	—
7	Temperature cycle	Endurance test applying the low and high temperature cycle. 	-30°C /80°C 10 cycles	—
Mechanical Test				
8	Vibration test	Endurance test applying the vibration during transportation and use.	10~22Hz→1.5mmp-p 22~500Hz→1.5G Total 0.5hrs	—
9	Shock test	Constructional and mechanical endurance test applying the shock during transportation.	50G Half sign wave 11 msdc 3 times of each direction	—
10	Atmospheric pressure test	Endurance test applying the atmospheric pressure during air transportation.	115mbar 40hrs	—
Others				
11	Static electricity test	Endurance test applying the electrical stress to the terminal.	VS=800V,RS=1.5kΩ CS=100pF 1 time	—

## 10. Backlight Information

(Ta=25°C)

PARAMETER	SYMBOL	MIN.	TYP.	MAX.	UNIT	TEST CONDITION
Luminous intensity	IV	150	200	--	CD/M <sup>2</sup>	ILED=107mA
Wave length	X	0.280				ILED=107mA
	Y	0.290				
Life time	--	--	50K	100K	Hr.	V <sub>≤</sub> 5Vdc
Color	White					

## 11. Touch Panel Information

- NOTES:
1. NO GLASS THICKNESS : 1.1mm
  2. NO PET TOP CIRCUIT THICKNESS : 0.2mm
  3. SPACER ADHESIVE : 0.1mm
  4. OVERBALL THICKNESS : 1.40mm ±0.07
  5. CONNECTOR AND PINOUT AS INDICATED
  6. FRONT SURFACE ANGLE ARE INDICATED
  7. OPTICAL SPECIFICATION : ABOUT
  8. LAYER TO LAYER ASSEMBLY TOLERANCE : ±0.3mm

Pre #	Assignment
1	Right
2	Left
3	Bottom
4	Top

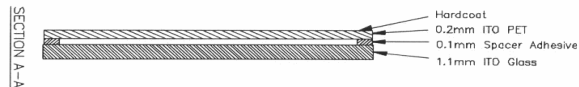
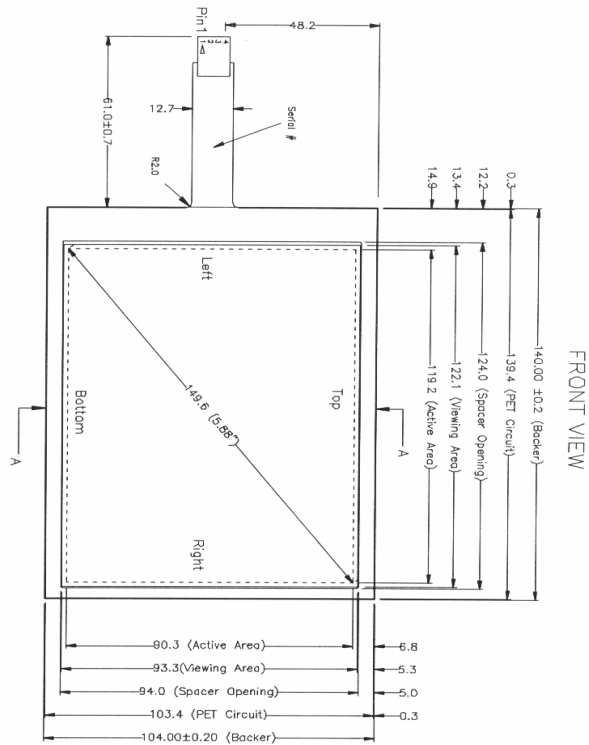

## 11.1 Machine Specifications

ITEM	SPECIFICATION	CONDITION
Operating force	Less than 80g	R8.0 HS 40 ° Silicon rubber or R0.8 Polyacetal pen
Surface hardness	More than 2H	Pencil test
Light transmission	More than 80%	@550nm Hitachi U3300
Durability for pen selections	More than 1,200,000 times	Force:250g Speed:2cm/sec