

## SiliconDrive™ PC Card: 128MB to 8GB of Solid-State Storage

### Overview

SiliconDrive™ PC Card products replace the functionality of rotating hard disk drives while providing enhanced levels of performance and reliability for Enterprise System OEMs targeting the netcom, military, industrial, interactive kiosk and medical markets. Typical end-market applications include broadband data and voice networks, military systems, flight system avionics, medical equipment, industrial control systems, and interactive kiosks.

SiliconDrives are designed to meet the growing OEM demands for high performance, high reliability, multi-year product lifecycles, low power consumption, compact size, and reliable operation in extreme environments. SiliconDrive PC Card Type II form factor products are available in capacities ranging from 128MB to 8GB.

SiliconSystems patented and patent-pending technology advances of data sanitization and purge, write protection, drive integrity in the event of unexpected power loss, and application-specific performance enhancements are available as options on all SiliconDrive products. Separate application notes covering these topics are available under NDA.



### Features

- ATA-3 Compliant
- Capacity Range: 128MB to 8GB
- Supports Both 8 and 16 Bit Data Register Transfers
- Supports Dual Voltage 3.3V or 5V Interface
- Less than 1 Error in  $10^{14}$  Bits Read
- MTBF > 4,000,000 Hours
- Industry Standard Type II PC Card Form Factor
- Solid-State, No Moving Parts
- Supports PIO Modes 0-4 and Optional DMA Modes 0-2
- High Shock & Vibration Tolerance

# 1. PHYSICAL SPECIFICATIONS

SiliconDrive PC Card products are offered in an industry standard PC Card Type II form factor. Refer to Section 10.1 Part Ordering Nomenclature for details regarding PC Card capacities.

## 1.1. Physical Dimensions

The following diagram describes the PC Card Type II physical dimensions and pin orientation:

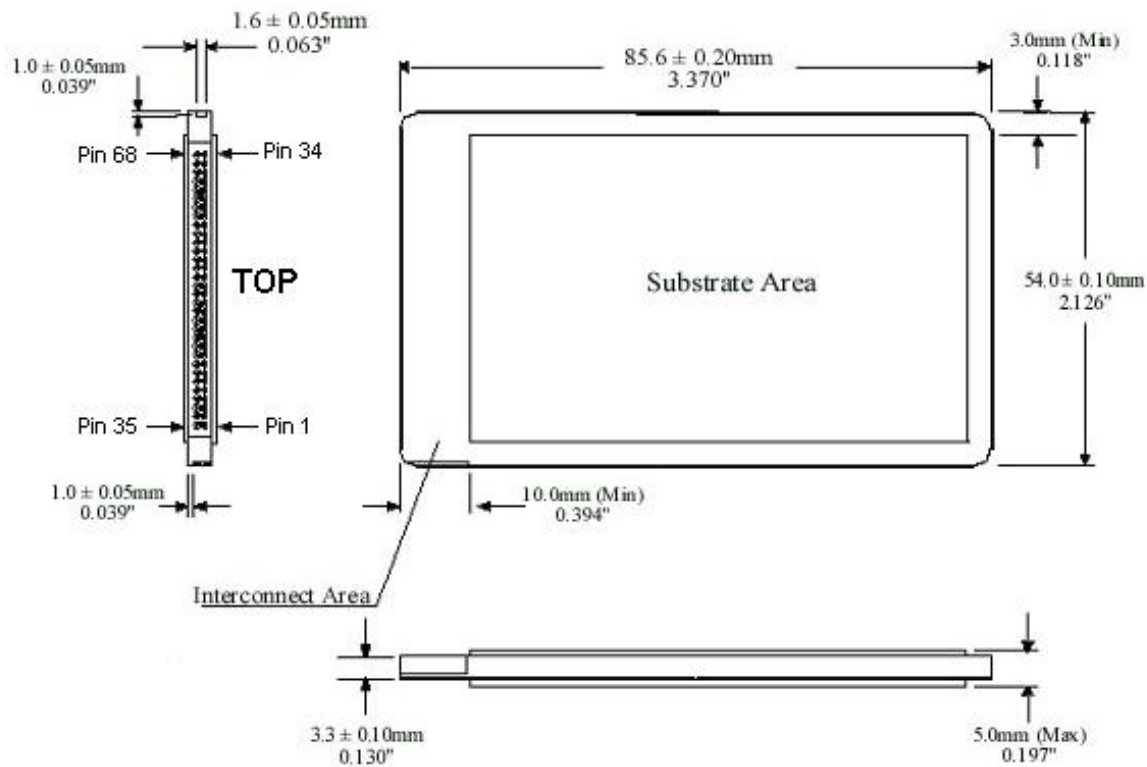

## 2. PRODUCT SPECIFICATIONS<sup>1</sup>

### 2.1. System Performance

Reset to Ready Startup Time (Typical/Max)	200ms/400ms
Read Transfer Rate (Typical)	8MB/s
Write Transfer Rate (Typical)	6MB/s
Burst Transfer Rate	16.7MB/s
Controller Overhead (Command to DRQ)	2ms (max)

### 2.2. System Power Requirements

DC Input Voltage	3.3 ± 5%	5.0 ± 10%
Sleep (Standby Current)	<0.5mA	<1.0mA
Read (Typical/Peak)	20mA/75mA	30mA/100mA
Write (Typical/Peak)	30mA/75mA	40mA/100mA

### 2.3. System Reliability

MTBF (@ 25°C)	> 4,000,000 Hours
Data Reliability	< 1 Non-Recoverable Error in 10 <sup>14</sup> Bits Read
Endurance	>2,000,000 write/erase cycles

<sup>1</sup> All SiliconDrive PC Card values quoted are typical at 25°C and nominal supply voltage.

## 2.4. Product Capacity Specifications

Product Density	Formatted Capacity (Bytes)	Number of Sectors	Number of Cylinders	Number of Heads	Number of Sectors/Track
128MB	130,154,496	254,208	993	8	32
256MB	260,571,136	508,928	994	16	32
512 MB	521,773,056	1,019,088	1011	16	63
1GB	1,047,674,880	2,046,240	2030	16	63
2GB	2,098,446,336	4,098,528	4066	16	63
4GB	4,224,761,856	8,251,488	8186	16	63
6GB	6,309,789,696	12,323,808	12226	16	63
8GB	8,456,749,056	16,517,088	16386	16	63

## 2.5. Environmental Specifications

<b>Temperature</b>	0°C to 70°C (Standard)
	-40°C to 85°C (Industrial)
<b>Humidity</b>	8% to 95% non-condensing
<b>Vibration</b>	16.3gRMS, MIL-STD-810F, Method 514.5, Procedure I, Category 24
<b>Shock</b>	1000G, Half-sine, 0.5ms Duration 50g Pk, MIL-STD-810F, Method 516.5, Procedure I
<b>Altitude</b>	80,000ft, MIL-STD-810F, Method 500.4, Procedure II

## 10. SALES AND SUPPORT

To order or to obtain information on pricing and delivery, please contact your SiliconSystems Sales Representative.

### 10.1. Part Numbering Nomenclature

The following table defines the SiliconDrive PC Card part numbering scheme:

Definition						
SSD-	P	XXX	T	-YYYY		
<i>SiliconSystems Proprietary</i>						
<i>Temp. Range: Blank=Commercial, I=Industrial</i>						
<i>Capacity: 08G=8GB / 128=12M</i>						
<i>Form Factor: P = PC Card</i>						
<b>SiliconSystems SiliconDrive</b>						
<i>Operating Temperature Range: Commercial: 0°C to 70°C, Industrial: -40°C to +85°C</i>						
<i>Note: YYYY = -3005 for Standard SiliconDrive PC Card</i>						

Part Number	Description
SSD-P08G-3005	8GB SiliconDrive PC Card, Commercial Temp
SSD-P06G-3005	6GB SiliconDrive PC Card, Commercial Temp
SSD-P04G-3005	4GB SiliconDrive PC Card, Commercial Temp
SSD-P02G-3005	2GB SiliconDrive PC Card, Commercial Temp
SSD-P01G-3005	1GB SiliconDrive PC Card, Commercial Temp
SSD-P51M-3005	512MB SiliconDrive PC Card, Commercial Temp
SSD-P25M-3005	256MB SiliconDrive PC Card, Commercial Temp
SSD-P12M-3005	128MB SiliconDrive PC Card, Commercial Temp

SiliconSystems' performance tests, ratings and product specifications are measured using specific computer systems and/or components and reflect the approximate performance of SiliconSystems' products as measured by those tests. Any difference in system hardware or software design or configuration, as well as system use, may affect actual test results, ratings and product specifications. SiliconSystems may change its product specifications or its products at any time and without notice.

SiliconSystems™, SiliconDrive™, SiliconDrive Module™, and the SiliconSystems logo are trademarks or registered trademarks of SiliconSystems and may be used publicly only with permission from SiliconSystems and require proper acknowledgement. Other listed names and brands are trademarks or registered trademarks of their respective owners.